

# HI-STAR 7A: A Robust Container for Storage, Disposal and Transportation of Class A RadWaste Material



Holtec International's HI-STAR 7A is designed for the on-site storage, and/or transportation for disposal of low level radioactive solid waste to a licensed disposal facility for final disposition. Fully qualified as a U.S. Department of Transportation (DOT) Specification 7A Type A Container, the HI-STAR 7A offers the user a solution to meet the nuclear industry's waste disposal needs.



Designed and manufactured into a robust metal box, HI-STAR 7A has smooth outer surfaces to allow for easy decontamination. Its internal volume also has the capacity to package four times that of a typical load provided by the standard B-25 LSA Box. This reduces the number of overall waste packages helping to lower overall transportation costs.

**HI-STAR 7A Ready for Use at Holtec's Oyster Creek Decommissioning Site**

The HI-STAR 7A may be used as a temporary on-site storage container. Additionally, Holtec's HI-STAR 7A and its contents of Class A waste material can be transported to a licensed disposal facility where, upon arrival, it is interred into the disposal cavity in accordance with the Disposal Site's Waste Acceptance Criteria.

The HI-STAR 7A may be used as a temporary on-site storage container. Additionally, Holtec's HI-STAR 7A and its contents of Class A waste material can be transported to a licensed disposal facility where, upon arrival, it is interred into the disposal cavity in accordance with the Disposal Site's Waste Acceptance Criteria.

HI-STAR 7A is designed to hold solid radwaste material that can range from large bulk items and high density metals to irradiated metal and hardware debris generated during reactor segmentation activities and dismantling of other metallic waste forms. Its wall thickness comes in two sizes, 0.75" and 1.5", to accommodate the varying radiation levels of the packaged waste materials produced by a typical nuclear site. The HI-STAR 7A may be lifted and moved by crane using the four standard lift rings located on the lid or, since it is delivered on skids, moved using a forklift.

In addition to being a U.S. DOT qualified container, HI-STAR 7A meets all the specification and general packaging requirements established in 49 CFR 179.350 and additional design requirements specified in 49CFR173.410, 411, and 412 as well as the testing requirements of 49CFR173.465.

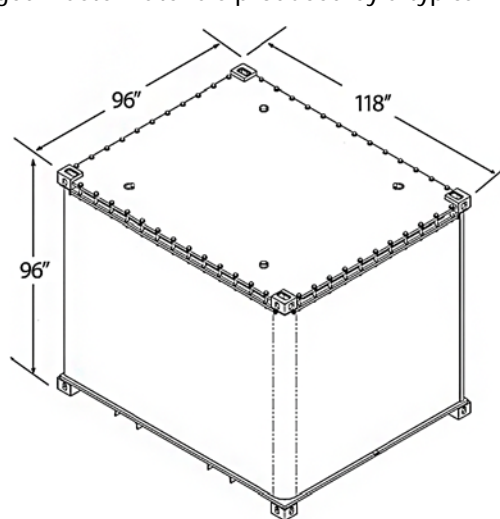

Outer Cavity Dimensions

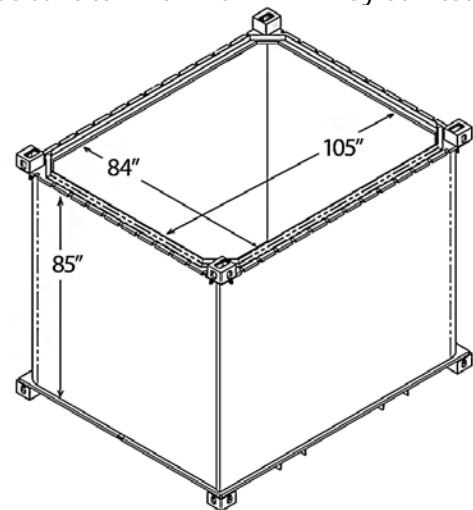

Inner Cavity Dimensions

**Outer and Inner Dimensions of Holtec's HI-STAR 7A with 1.5" Thick Walls**

*This Holtec Technical Information Bulletin is copyrighted by Holtec International. All innovative design features of the device described herein are subject to intellectual property protection under U.S. and international laws on patent rights. For more information, contact Joy Russell, j.russell@holtec.com, +1-856-797-0900, Ext. 3655, [www.holtecinternational.com](http://www.holtecinternational.com); September/2020 Rev 1*