

(12) **United States Patent**
Singh et al.

(10) **Patent No.:** **US 9,770,794 B2**
 (45) **Date of Patent:** **Sep. 26, 2017**

(54) **VERTICAL BUNDLE AIR COOLED HEAT EXCHANGER, METHOD OF MANUFACTURING THE SAME, AND POWER GENERATION PLANT IMPLEMENTING THE SAME**

(52) **U.S. Cl.**
 CPC **B23P 15/26** (2013.01); **B21C 23/00** (2013.01); **F28B 1/06** (2013.01); **F28B 9/10** (2013.01);

(Continued)

(75) **Inventors:** **Krishna P. Singh**, Hobe Sound, FL (US); **Indresh Rampall**, Cherry Hill, NJ (US); **Joseph Rajkumar**, Marlton, NJ (US); **Frank David Sanderlin**, San Diego, CA (US)

(58) **Field of Classification Search**
 CPC ... **B23P 15/26**; **F28F 1/003**; **F28F 1/16**; **F28F 1/20**; **F28F 2215/04**; **F28F 2275/125**;
 (Continued)

(73) **Assignee:** **HOLTEC INTERNATIONAL**

(56) **References Cited**

(*) **Notice:** Subject to any disclaimer, the term of this patent is extended or adjusted under 35 U.S.C. 154(b) by 898 days.

U.S. PATENT DOCUMENTS

3,887,004 A 6/1975 Beck
 4,419,802 A * 12/1983 Riese B21C 37/151
 165/179

(Continued)

(21) **Appl. No.:** **14/123,678**

Primary Examiner — Moshe Wilensky

(22) **PCT Filed:** **Jun. 4, 2012**

(74) *Attorney, Agent, or Firm* — The Belles Group, P.C.

(86) **PCT No.:** **PCT/US2012/040806**

§ 371 (c)(1),
 (2), (4) **Date:** **Jun. 17, 2014**

(57) **ABSTRACT**

A vertical bundle air-cooled heat exchanger, In one embodiment, the invention can be a vertical bundle assembly comprising: at least one tube bundle assembly comprising; a tube bundle comprising a plurality of finned tubes arranged in a substantially vertical and side-by-side orientation, each of the plurality of finned tubes comprising a cavity; a top header pipe comprising an inlet header cavity operably coupled to a source of steam; a bottom header pipe comprising an outlet header cavity for collecting condensate; top ends of the plurality of finned tubes coupled to the top header pipe and the bottom ends of the plurality of finned tubes coupled to the bottom header pipe; and, a shell having an open, top end and open bottom end, the at least one tube bundle assembly positioned within the shell.

(87) **PCT Pub. No.:** **WO2012/167279**

PCT Pub. Date: **Dec. 6, 2012**

(65) **Prior Publication Data**

US 2015/0360332 A1 Dec. 17, 2015

Related U.S. Application Data

(60) **Provisional application No.** 61/493,208, filed on Jun. 3, 2011.

(51) **Int. Cl.**
B23P 15/26 (2006.01)
F28D 7/10 (2006.01)

(Continued)

19 Claims, 10 Drawing Sheets

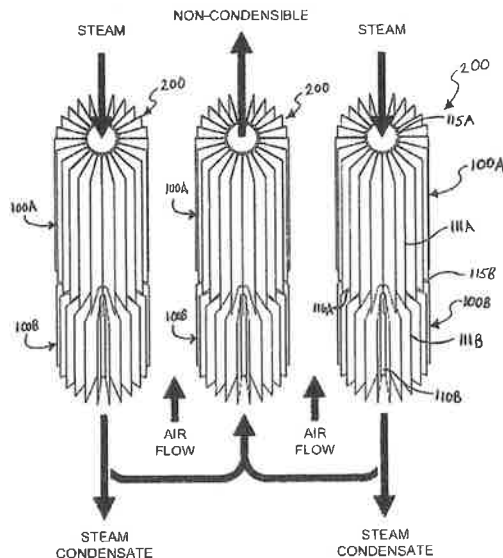

- (51) **Int. Cl.**
F28B 1/06 (2006.01)
F28B 9/10 (2006.01)
F28F 1/16 (2006.01)
F28F 1/20 (2006.01)
F28D 1/02 (2006.01)
B21C 23/00 (2006.01)
F28F 1/00 (2006.01)

- (52) **U.S. Cl.**
 CPC *F28D 1/024* (2013.01); *F28D 7/10*
 (2013.01); *F28F 1/003* (2013.01); *F28F 1/16*
 (2013.01); *F28F 1/20* (2013.01); *F28F*
2215/04 (2013.01); *F28F 2275/125* (2013.01);
Y10T 29/4938 (2015.01); *Y10T 29/49393*
 (2015.01)

- (58) **Field of Classification Search**
 CPC ... B21C 23/00; F28B 9/10; F28B 1/06; F28D
 1/024; F28D 7/10
 See application file for complete search history.

(56) **References Cited**

U.S. PATENT DOCUMENTS

| | | | | |
|--------------|------|---------|-----------------|--------------------------------|
| 5,606,792 | A | 3/1997 | Schafer | |
| 6,155,339 | A | 12/2000 | Grapengater | |
| 6,332,494 | B1 | 12/2001 | Bodas et al. | |
| 8,069,678 | B1 * | 12/2011 | Bernert | <i>F28F 9/0282</i> 62/50.2 |
| 2009/0049846 | A1 | 2/2009 | Jensen | |
| 2010/0236766 | A1 * | 9/2010 | Ulics, Jr. | <i>F28D 1/05383</i> 165/173 |

* cited by examiner

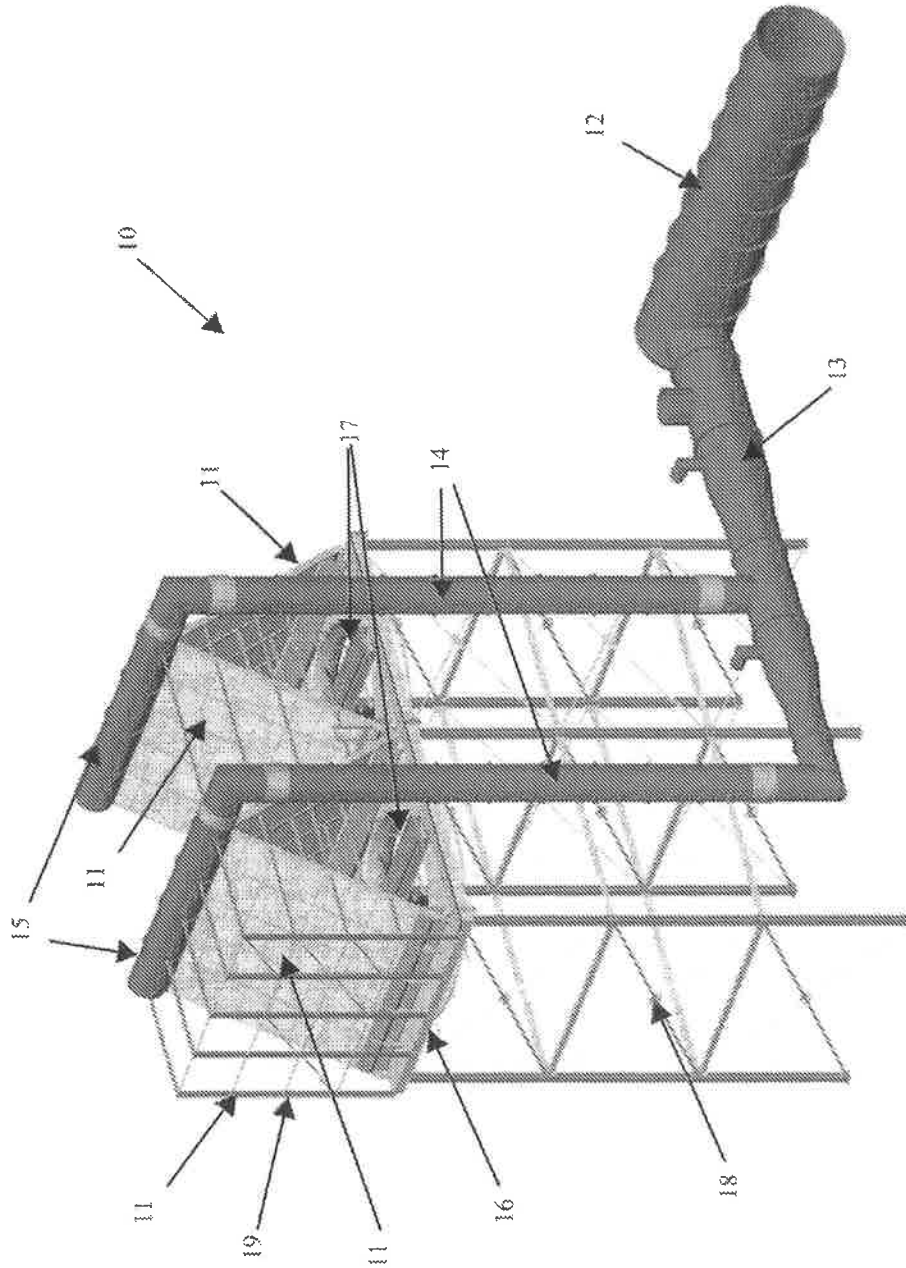

FIGURE 1 (PRIOR ART)

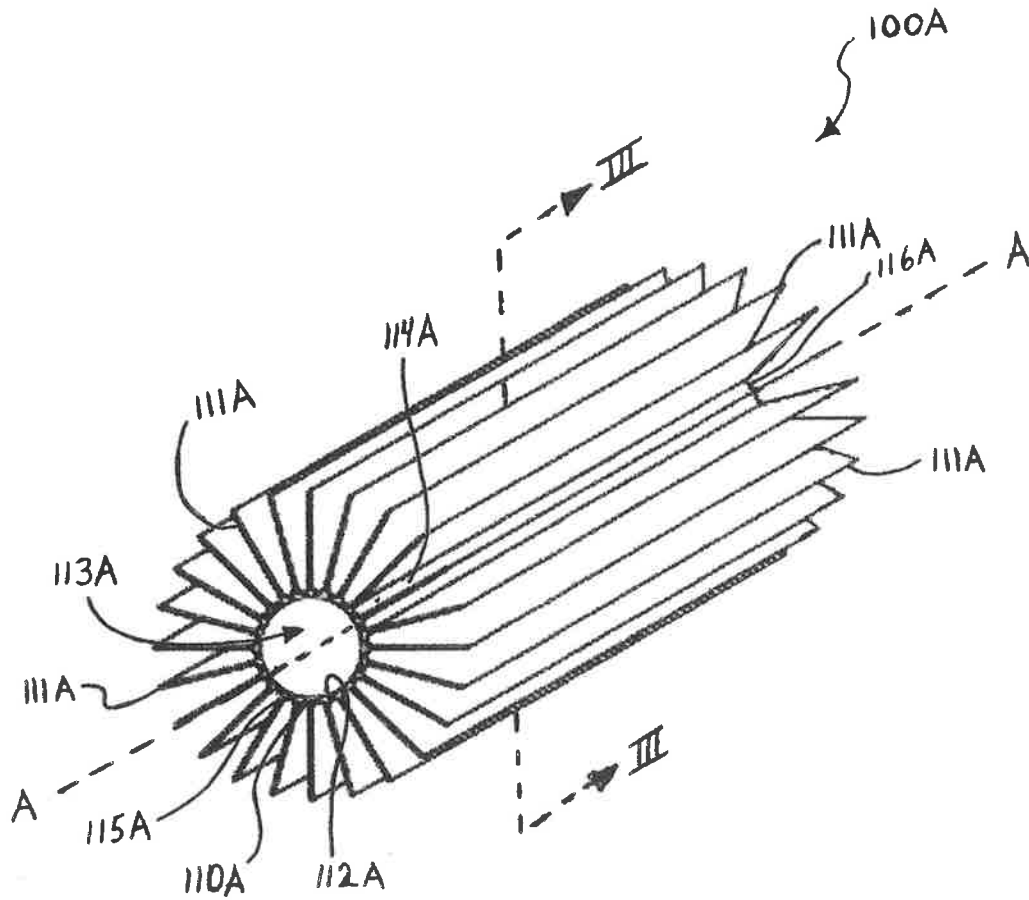

FIGURE 2

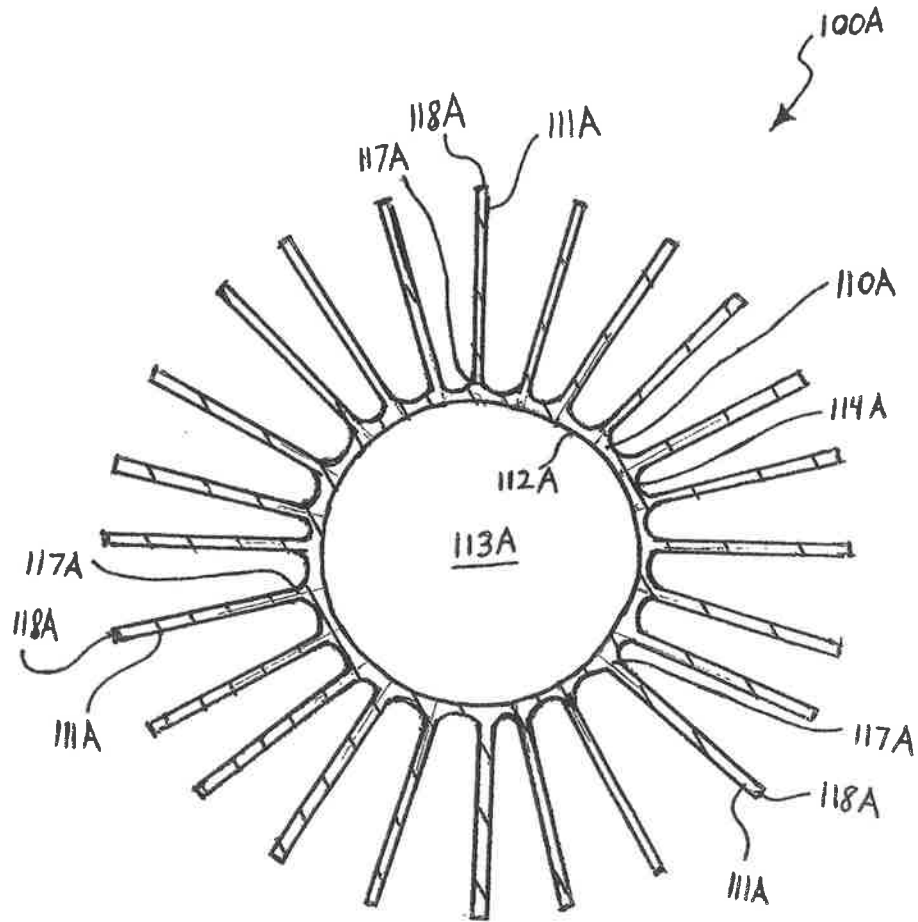

FIGURE 3

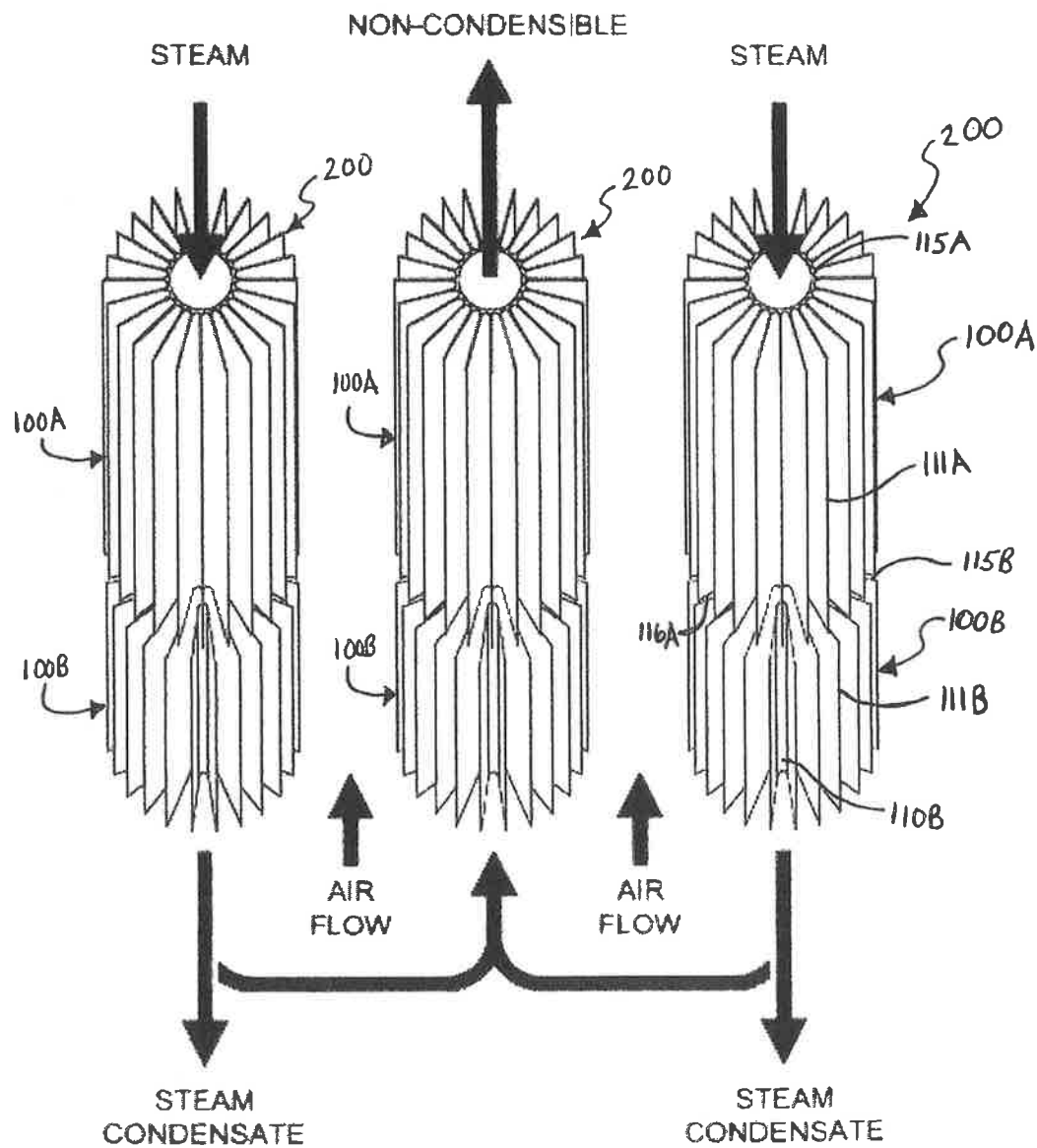

FIGURE 4

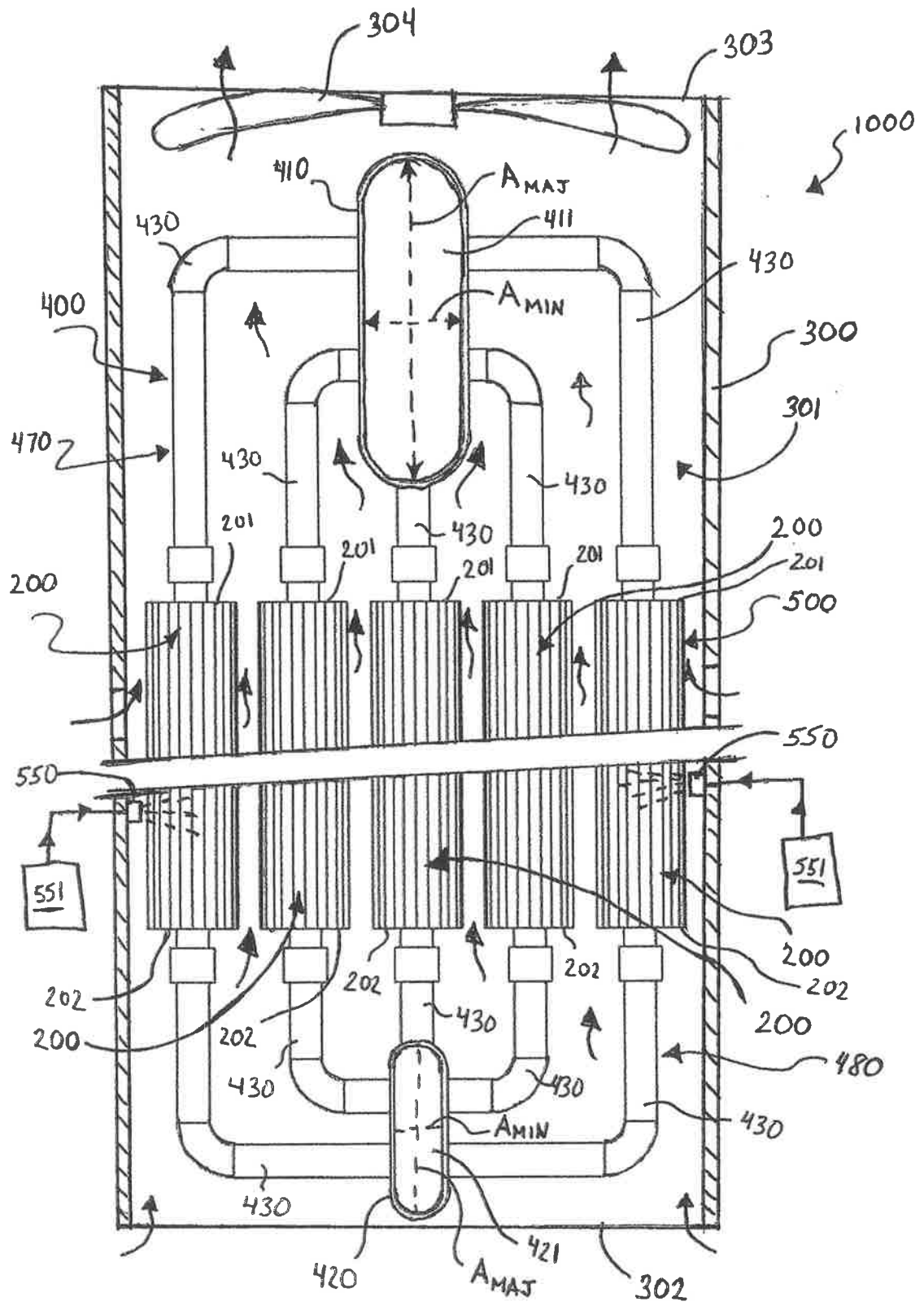

FIGURE 5

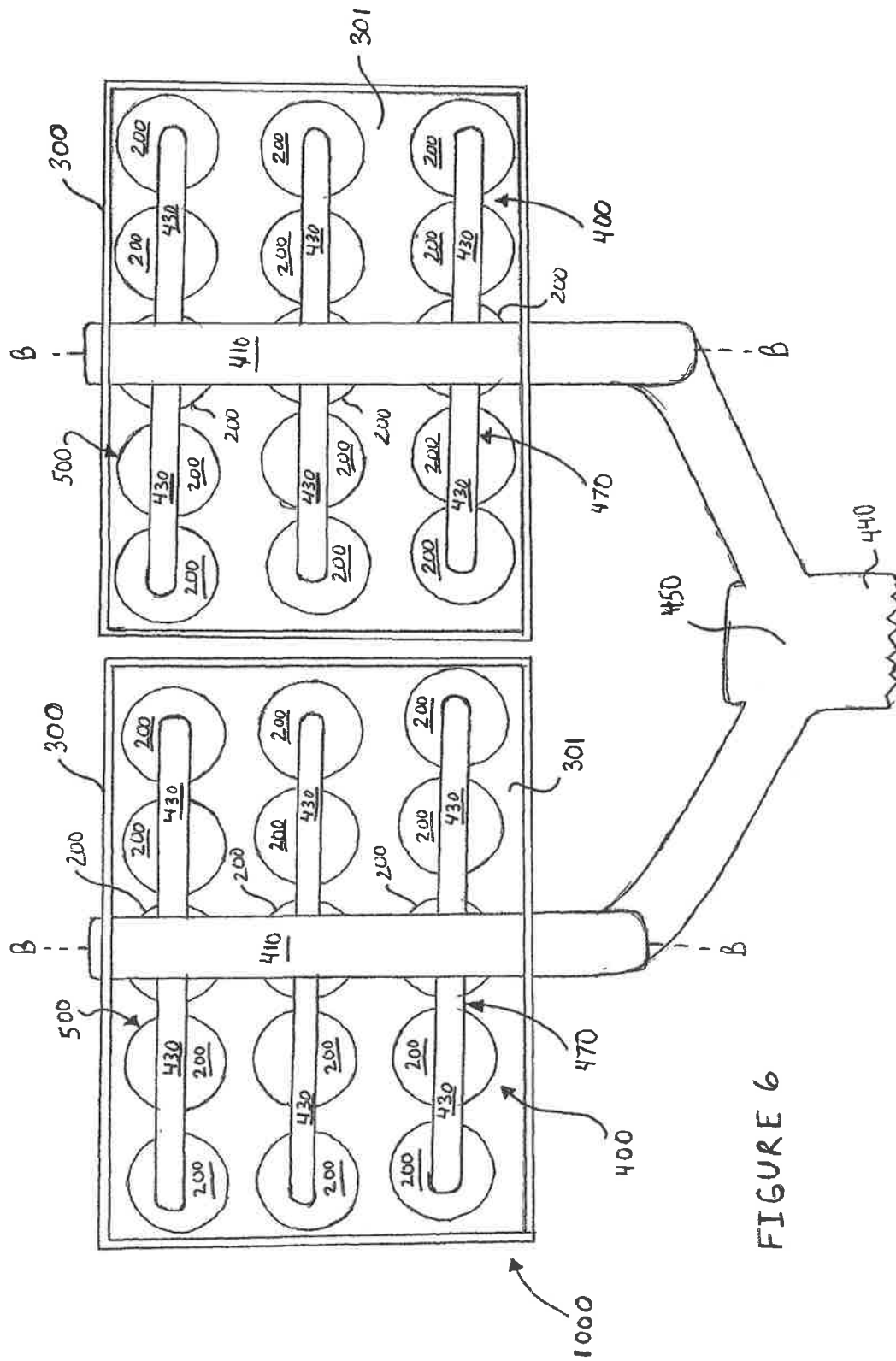

FIGURE 6

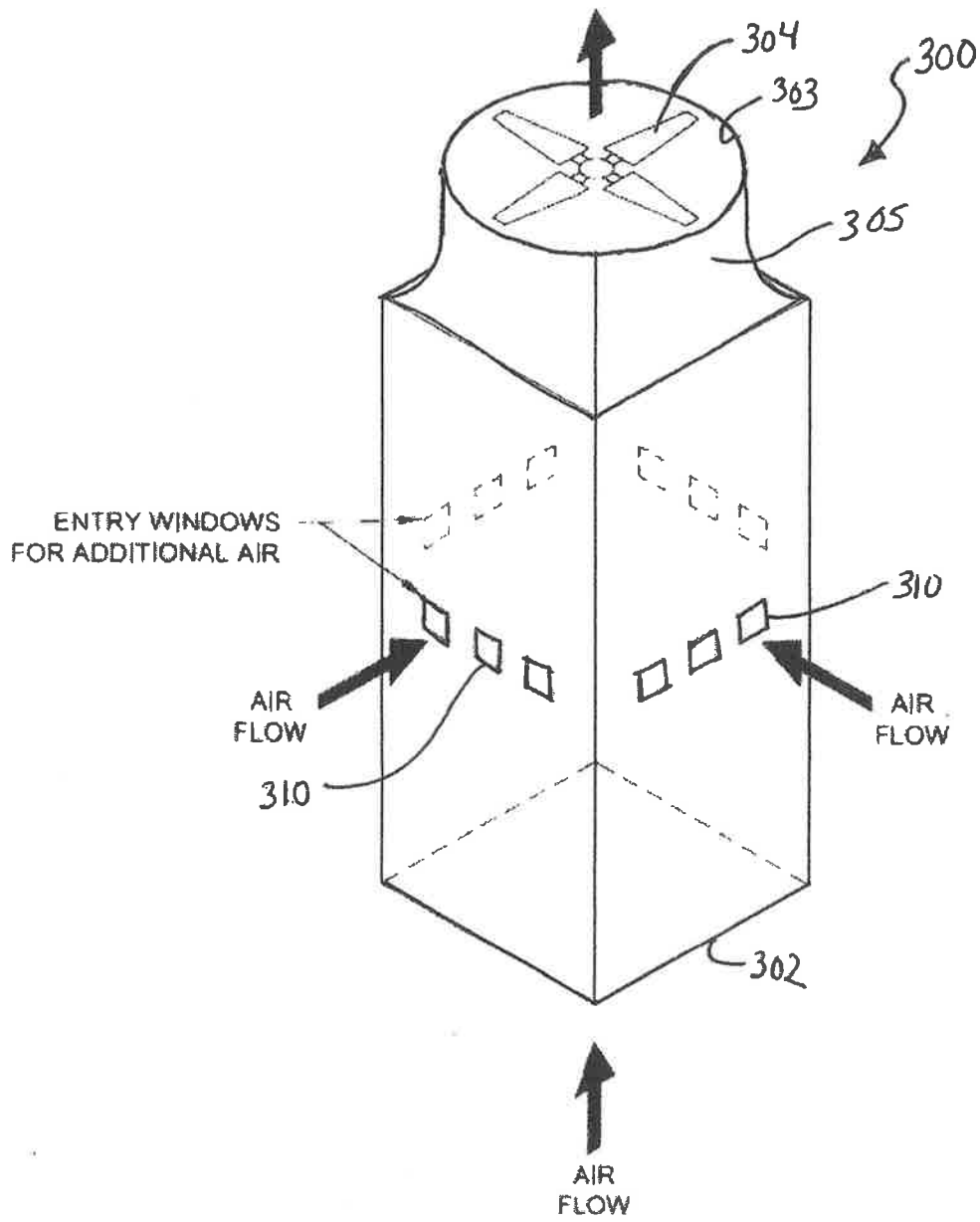

FIGURE 7

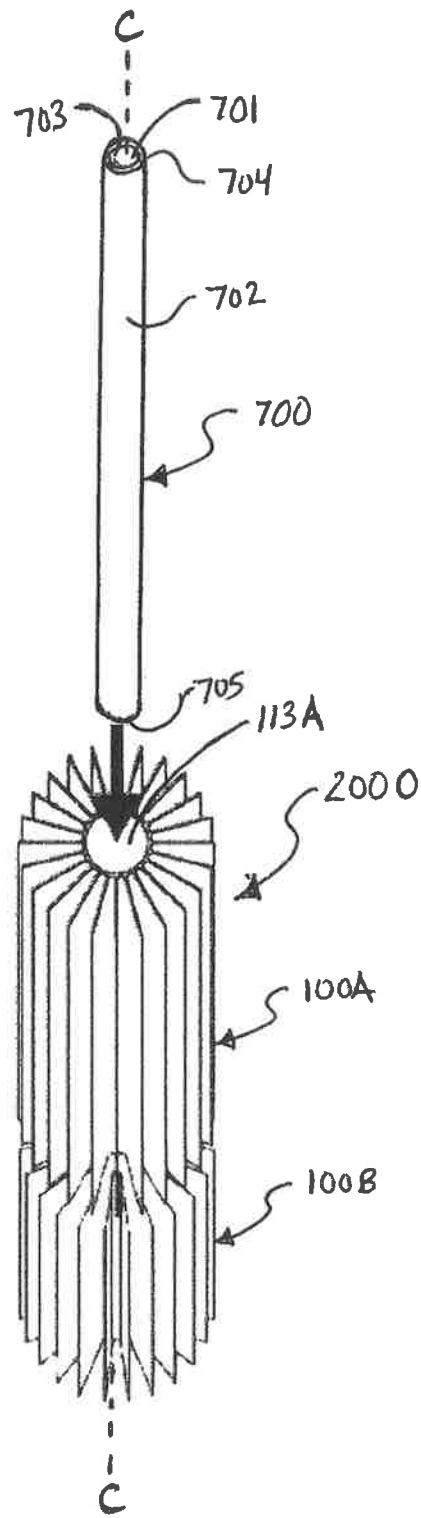

FIGURE 8

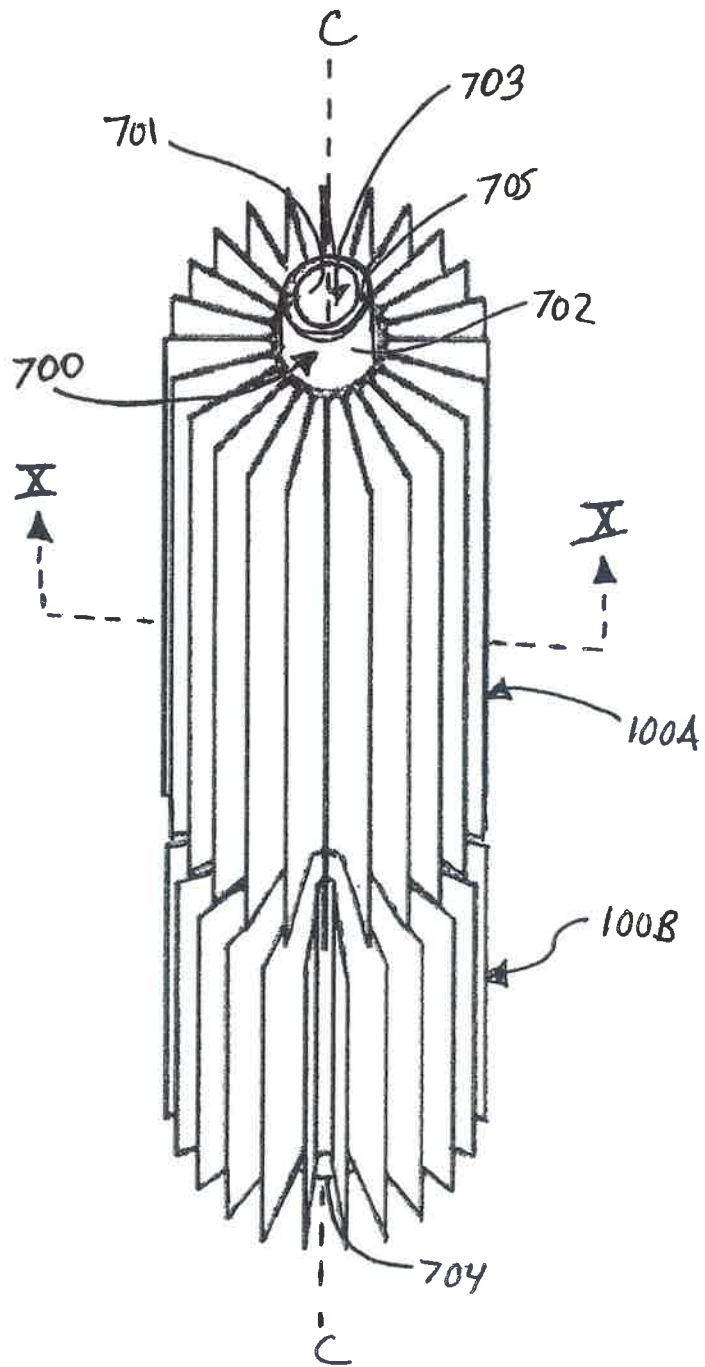

FIGURE 9

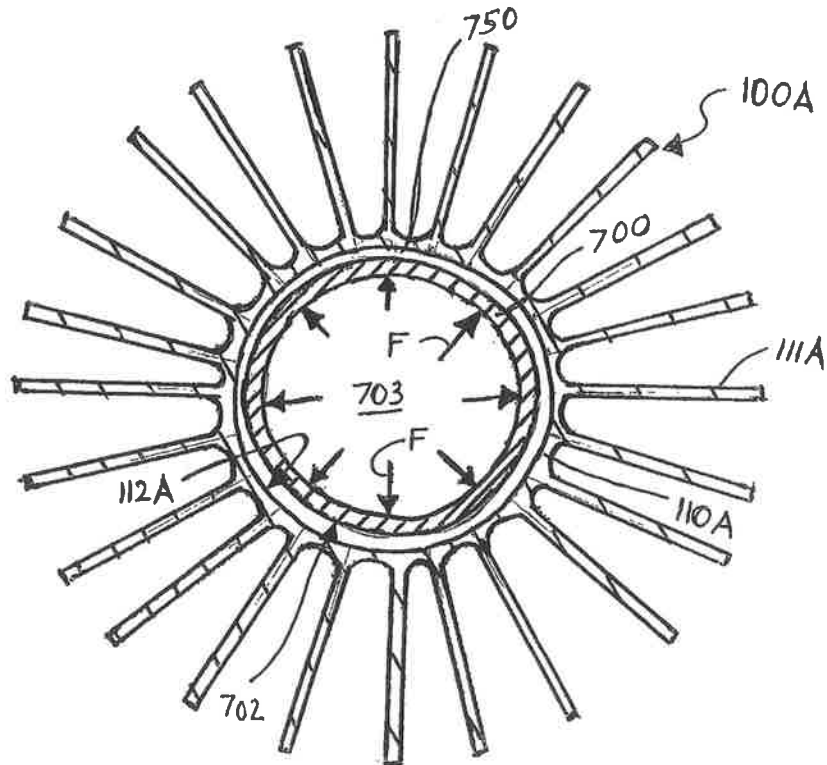

FIGURE 10

**VERTICAL BUNDLE AIR COOLED HEAT
EXCHANGER, METHOD OF
MANUFACTURING THE SAME, AND
POWER GENERATION PLANT
IMPLEMENTING THE SAME**

**CROSS-REFERENCE TO RELATED PATENT
APPLICATIONS**

This application claims the benefit of U.S. Provisional Patent Application No. 61/493,208, filed Jun. 3, 2011, the entirety of which is incorporated herein by reference.

FIELD OF THE INVENTION

The present invention relates generally to vertical bundle air-cooled heat exchangers, and specifically to vertical bundle air-cooled heat exchangers that act as the condensing unit in a Rankine cycle fluid circuit of a power generation plant.

BACKGROUND OF THE INVENTION

Cooling fluid streams by air instead of water is an inherently more environmentally friendly option. Indeed, restriction on water consumption for industrial use, especially to condense waste steam in power plants, has emerged as a growing worldwide problem. Driven by increasing scarcity of water, power plant designers have been turning to air-cooled condensers, such as that which is shown in FIG. 1 in lieu of the conventional water-cooled condensers. Existing air-cooled condensers consist of inclined tube bundles organized in "cells" wherein the turbine exhaust steam flows inside the tubes and is condensed by the flow of cooling air in a cross flow mode delivered by axial fans located underneath. A typical air-cooled condenser unit 10 is shown in FIG. 1 and comprises a plurality of inclined tube bundles 11 arranged in an A-frame structure. A main stem duct 12 delivers steam from a turbine into a distribution manifold 13. The steam passes through the distribution manifold 13 and into the risers 14, where it then flows into the distribution headers 15. The distribution headers 15 deliver the steam into the inclined tube bundles 11 where thermal energy from the steam is transferred to air flowing on the outside of the inclined tube bundles 11. The tube bundles 1 are positioned atop a fan deck platform 16 that comprises a plurality fans 17 for forcing cooling air to flow adjacent and through the inclined tube bundles 11. The fan deck platform may be situated atop a frame 18 so that cooling air can be drawn upward. A windwall structure 19 may also be provided.

Prior air-cooled condenser configurations have several disadvantages that have limited its wide application, such as: (1) high capital cost; (2) large land area requirement; (3) significant site construction effort; and (4) contamination of condensate (deleterious iron carry over) by corrosion of the carbon steel tubing and associated reduction in the service life of the system.

Thus, a need for an improved air-cooled heat exchanger, and improved finned tubes for use with the same, exists.

SUMMARY OF THE INVENTION

In one embodiment, the invention can be a method of forming a finned tube for an air-cooled condenser, the method comprising: extruding, from a first material, a first finned tube section comprising: a first tube having an inner

surface forming a first cavity along a first longitudinal axis and an outer surface; and a first plurality of fins protruding radially outward from the outer surface of the first tube, the first plurality of fins integral with the first tube and extending substantially parallel to the first longitudinal axis.

In another embodiment, the invention can be a method of forming a finned tube for an air-cooled condenser, the method comprising: providing a finned tube section comprising: an outer tube having an inner surface forming a cavity along a longitudinal axis and an outer surface; and a plurality of fins protruding radially outward from the outer surface of the outer tube, the outer tube formed of a first material; inserting an inner tube having an outer surface through the cavity of the outer tube, the inner tube having an inner surface forming a cavity; and expanding the inner tube so that the outer surface of the inner tube is in contact with the inner surface of the outer tube, the inner tube formed of a second material that is different than the first material.

In yet another embodiment, the invention can be a method of forming a finned tube for an air-cooled condenser, the method comprising: forming a plurality of finned tube sections, each of the finned tube sections comprising: a tube having an inner surface forming a cavity along a longitudinal axis and an outer surface; and a plurality of fins protruding radially outward from the outer surface of the tube; aligning the plurality of finned tube sections so that the longitudinal axes are in axial alignment and the plurality of fins of adjacent finned tube sections are angularly offset from one another; and coupling the plurality of finned sections together.

In still another embodiment, the invention can be a method of forming a tube bundle assembly for an air-cooled condenser comprising: forming a plurality of finned tubes in accordance with one of the methods described in the three paragraphs immediately preceding above; arranging the plurality of finned tubes in a substantially vertical and side-by-side orientation; coupling a top end of the outer tube of each of the plurality of finned tubes to a top header pipe and coupling a bottom end of the outer tube of each of the plurality of finned tubes to a bottom header pipe; wherein a hermetic fluid path is formed through the cavity of the inner tube of each of the plurality of finned tubes from an inlet header cavity of the top header pipe to an outlet header of the bottom header pipe.

In even another embodiment, the invention can be a method of condensing steam in a power generation plant comprising: introducing steam into the inlet header cavity of the tube bundle assembly formed by the method described in the immediately preceding paragraph, the steam flowing downward through the hermetic fluid paths of the plurality of finned tubes; flowing air upward along the plurality of finned tubes of the tube bundle assembly, thermal energy being transferred from the steam to the air through the plurality of finned tubes, thereby condensing the steam; and condensate gathering in the outlet header cavity of the bottom header pipe.

In a further embodiment, the invention can be a finned tube for an air-cooled condenser comprising: an extruded first finned tube section comprising: a first tube having an inner surface forming a first cavity along a first longitudinal axis and an outer surface; and a first plurality of fins protruding radially outward from the outer surface of the first tube, the first plurality of fins integral with the first tube and extending substantially parallel to the first longitudinal axis; and wherein the extruded finned section is formed of a first material.

3

In a yet further embodiment, the invention can be a finned tube for an air-cooled condenser comprising: an outer tube having an inner surface forming a cavity along a longitudinal axis and an outer surface; a plurality of fins protruding radially outward from the outer surface of the outer tube, the outer tube formed of a first material; an inner tube extending through the cavity of the outer tube, the inner tube having an inner surface forming a cavity and an outer surface, the outer surface of the inner tube being in contact with the inner surface of the outer tube, the inner tube formed of a second material that is different than the first material.

In a still further embodiment, the invention can be a finned tube for an air-cooled condenser comprising: a plurality of finned tube sections, each finned tube section comprising: an outer tube having an inner surface forming a cavity along a longitudinal axis and an outer surface, the outer tube formed of a first material; and a plurality of fins protruding radially outward from the outer surface of the outer tube; and an inner tube extending through the cavities of the outer tubes to couple the plurality of finned tube sections together, the inner tube having an inner surface forming a cavity and an outer surface, the outer surface of the inner tube being in contact with the inner surfaces of the outer tubes, the inner tube formed of a second material that is different than the first material.

In an even further embodiment, the invention can be a finned tube for an air-cooled condenser comprising: a plurality of finned tube sections, each finned tube section comprising: an outer tube having an inner surface forming a cavity along a longitudinal axis and an outer surface, the outer tube formed of a first material; and a plurality of fins protruding radially outward from the outer surface of the outer tube; and the plurality of finned tube sections coupled together in a manner so that the longitudinal axes are in axial alignment and the plurality of fins of adjacent finned tube sections are angularly offset from one another.

In other embodiments, the invention can be a tube bundle assembly for an air-cooled condenser comprising: a plurality of finned tubes in accordance with any one of the immediately preceding four paragraphs, the plurality of finned tubes arranged in a substantially vertical and side-by-side orientation; a top end of each of the plurality of finned tubes coupled to a top header pipe and a bottom end of each of the plurality of finned tubes coupled to a bottom header pipe; and wherein a hermetic fluid path is formed through each of the plurality of finned tubes from an inlet header cavity of the top header pipe to an outlet header of the bottom header pipe.

In yet another embodiment, the invention can be a power generation plant comprising: at least one tube bundle assembly according to the immediately preceding paragraph, the top header pipe operably coupled to a source of steam generated during a power generation cycle; and a blower for flowing air upward along the plurality of finned tubes of the tube bundle assembly

In a still further embodiment, the invention can be an air-cooled condenser comprising: at least one tube bundle assembly comprising: a tube bundle comprising a plurality of finned tubes arranged in a substantially vertical and side-by-side orientation, each of the plurality of finned tubes comprising a cavity; a top header pipe comprising an inlet header cavity operably coupled to a source of steam; a bottom header pipe comprising an outlet header cavity for collecting condensate; wherein top ends of the plurality of finned tubes are coupled to the top header pipe and the bottom ends of the plurality of finned tubes are coupled to the bottom header pipe; and the top header pipe having a

4

transverse cross-section having a minor axis and a major axis, the minor axis of the transverse cross-section of the top header pipe extending substantially horizontal.

In another embodiment, the invention can be a vertical bundle air-cooled condenser comprising: at least one tube bundle assembly comprising: a tube bundle comprising a plurality of finned tubes arranged in a substantially vertical and side-by-side orientation, each of the plurality of finned tubes comprising a cavity; a top header pipe comprising an inlet header cavity operably coupled to a source of steam; a bottom header pipe comprising an outlet header cavity for collecting condensate; top ends of the plurality of finned tubes coupled to the top header pipe and the bottom ends of the plurality of finned tubes coupled to the bottom header pipe; and a shell having an open top end and open bottom end, the at least one tube bundle assembly positioned within the shell.

In even another embodiment, the invention can be a power generation plant comprising: the vertical bundle air-cooled condenser according to any one of the two immediately paragraphs; and wherein the vertical bundle air-cooled condenser forms part of a Rankine cycle fluid circuit for producing power.

In a further embodiment, the invention can be an air-cooled condenser comprising: at least one tube bundle assembly comprising: a tube bundle comprising a plurality of finned tubes arranged in a substantially vertical and side-by-side orientation, each of the plurality of finned tubes comprising a cavity; a top network of pipes operably coupled to a source of steam; a bottom network of pipes for collecting condensate; wherein top ends of the plurality of finned tubes are coupled to the top network of pipes and the bottom ends of the plurality of finned tubes are coupled to the bottom network of pipes; and the top network of pipes and the bottom network of pipes having one or more pipes having a transverse cross-section having a minor axis and a major axis, the minor axis of the transverse cross-section of the top header pipe extending substantially horizontal.

Further areas of applicability of the present invention will become apparent from the detailed description provided hereinafter. It should be understood that the detailed description and specific examples, while indicating the preferred embodiment of the invention, are intended for purposes of illustration only and are not intended to limit the scope of the invention.

BRIEF DESCRIPTION OF THE DRAWINGS

The present invention will become more fully understood from the detailed description and the accompanying drawings, wherein:

FIG. 1 is a schematic of a prior art air-cooled condenser unit;

FIG. 2 is a perspective view of an extruded finned tube section according to an embodiment of the present invention;

FIG. 3 is a transverse cross-section of the extruded finned tube section of FIG. 2 taken along view III-III;

FIG. 4 is a perspective view of three finned tubes, each of the finned tubes formed by a plurality of the finned tube sections of FIG. 2 according to an embodiment of the present invention;

FIG. 5 is a schematic of an air-cooled condenser comprising a tube bundle assembly according to an embodiment of the present invention positioned within a shell and coupled to a source of steam generated in a Rankine cycle of a power generation plant;

FIG. 6 is a top view of the air-cooled condenser of FIG. 5 wherein multiple tube bundle assemblies are shown coupled to an inlet manifold at a single point or juncture;

FIG. 7 is a perspective view of a shell according to an embodiment of the present invention;

FIG. 8 is a perspective view of an inner tube being slid into two finned tube sections during an initial step of a finned tube formation method according to another embodiment of the present invention;

FIG. 9 is a perspective view of the inner tube extending through the two finned tube sections during a subsequent step of a finned tube formation method according to another embodiment of the present invention;

FIG. 10 is a transverse cross-section of the finned tube assembly of FIG. 9 taken along view X-X, wherein the inner tube has not yet been expanded.

DETAILED DESCRIPTION OF THE DRAWINGS

The following description of the illustrated embodiment(s) is merely exemplary in nature and is in no way intended to limit the invention, its application, or uses.

Referring first to FIGS. 2 and 3 concurrently, a finned tube section 100A according to an embodiment of the present invention is exemplified. The finned tube section 110A extends from a first end 115A to a second end 116A along a longitudinal axis A-A. In the exemplified embodiment, the finned tube section 100A is an elongated tubular structure that is substantially linear and particularly suitable for creating a vertical tube bundle for an air-cooled condenser of a power generation plant. As discussed below, in certain embodiments, a plurality of the finned tube sections 100A can be formed and coupled together in axial alignment to form a single finned tube. In one such embodiment, the finned tube sections 100A have a length between 4 to 8 feet and are installed vertically in such sections. The invention, however, is not so limited and, in certain embodiment, the finned tube section 100A can be formed of a sufficient length such that a single finned tube section 100A forms a single finned tube. In such an embodiment, the first end 115A of the finned tube section 100A will be the top end of the finned tube while the second end 116A of the finned tube section 100A will be the bottom end of the finned tube (or vice versa). As discussed below, the finned tube section 100A is a heat exchange tube in that it effectively transfers thermal energy from a tube-side fluid, such as steam, that is flowing inside of the finned tube section 100A to a shell-side fluid, such as air, that is flowing adjacent the finned tube section 100A on the exterior thereof.

The finned tube section 100A generally comprises a tube 110A and a plurality of fins 111A extending radially outward from the tube 110A. The tube 110A comprises an inner surface 112A that forms a cavity 113A and an outer surface 114A from which the plurality of fins 111A protrude/extend. The cavity 113A extends along a longitudinal axis A-A. In certain embodiments (i.e., embodiment in which an inner tube is not needed), the cavity 113A acts as a tube-side fluid path in which the inner surface 112A is exposed to the tube-side fluid. In embodiments in which an inner tube is used (described later with respect to FIGS. 8-11), the tube 110A can be considered an outer tube, the inner surface 112A of which is not exposed to the tube-side fluid (such as steam generated in a Rankine power cycle). In the exemplified embodiment, the tube 10 OA has a substantially circular transverse cross-section.

The tube 110A also comprises an outer surface 114A. The plurality of fins 111A protrude radially outward from the

outer surface 114A of the tube 110A. In one embodiment, the finned tube section 100A is formed by an extrusion process. As a result, the plurality of fins 111A are integral with the tube 110A. More specifically, in one such embodiment, both the tube 110A and the plurality of fins 111A are simultaneously formed in a single extrusion process using a first material, such as an extrudable metal or metal alloy. In one specific embodiment, the finned tube section 100A (including both the plurality of fins 111A and the tube 110A) are formed of a material having a coefficient of thermal conductivity. Suitable materials include, for example, aluminum or aluminum alloy. The utilization of an extruded finned tube section 100A allows for the compaction and simplification of the overall heat exchanger, as compared with the state of the art cross flow designs.

While forming the entirety of the finned tube section 100A by a single extrusion step is preferred in certain embodiments, the invention is not so limited in other embodiments. In certain other embodiments, the tube 110A may be extruded in one step and the fins 111A may be extruded subsequently or prior thereto during a separate step, and then subsequently coupled (directly or indirectly) to the tube 110A through brazing, welding, thermal fusion, mechanical coupling, or other processes. In still other embodiments, the tube 110A and the fins 111A can be formed separately by techniques other than extrusion, such as machining, bending, pressing, die-cutting, stamping, and/or combinations thereof.

In the exemplified embodiment, each of the plurality of fins 111A extends substantially parallel with the longitudinal axis A-A and covers the entire length of the tube 111A, wherein the length is measured from the first end 115A to the second end 116A. Moreover, each of the plurality of fins 111A extends radially outward from the outer surface 114A of the tube 110A in a linear fashion from a base portion 117A to a distal end 118A. The base portions 117A can be thicker than the remaining portions of the fins 111A, thereby promoting stability and conductive heat transfer into the fins 111A. In the illustrated embodiment, the fins 111A are linear in their longitudinal extension. However, in alternate embodiments, the fins 111A may be extruded or otherwise formed with an undulating (wave) geometry to promote heat transfer.

As can best be seen in FIG. 3, the plurality of fins 111A are arranged about the circumference of the outer surface 114A of the tube 110A at uniform angular intervals. In the illustrated embodiment, the twenty four (24) fins 111A are provided on the tube 110A so that an angular interval of approximately 15° exists between adjacent fins 111A. Of course, the exact number of fins 111A, along with the angular spacing between them can vary as needed. For example, depending on the diameter of the tube 110A and the heat duty demand, the number and height of the radial fins 111A can be selected. The tube 110A can have as many radial fins 111A as the state of the art extrusion technology will allow. In one exemplary embodiment, providing 24 fins 111A on a 1.5 inch nominal ID tube 110A, wherein each fin 111A is 1.5 inch high has been determined to be feasible. A larger number of fins may be achieved if a larger size tube is selected.

Referring now to FIG. 4, the formation of a finned tube 200 using a plurality of the finned tube sections 100A-B according to an embodiment of the present invention will be described. FIG. 4 illustrates three of these finned tubes 200, which are identical for the formation and structural purposes described herein, despite their different functionality when incorporated into a tube bundle. The arrows indicating steam

flow in the finned tubes **200** results from the arrangement shown in FIGS. 5-6, which will be described later in this document. For purposes of simplicity, only one of the finned tubes **200** will be described with the understanding that the discussion is applicable to all of the finned tubes **200** in FIG. 4 and/or used to form a tube bundle according to the present invention.

As exemplified, the finned tube **200** comprises two finned tube sections **100A**, **100B**. Finned tube section **100A** is described above with reference to FIGS. 2-3, and is referred to herein as a first finned tube section **100A**. Finned tube section **100B** (only a portion of which is shown in FIG. 4) is identical to finned tube section **100A** in all aspects but is either subsequently or previously formed using one of methods discussed above. The finned tube section **100B** is referred to herein as the second finned tube section **100B**. Like numbers are used to like parts of the first and second finned tube sections **100A**, **100B** with the exception that the suffix "B" is used to denote the parts of the second finned tube section **100B** rather than the suffix "A," which is used in FIGS. 2-3 to describe the first finned tube section **100A**.

As mentioned above, the finned tube **200** comprises a first finned tube section **100A** and a second finned tube section **100B** arranged in axial alignment. The first finned tube section **100A** and the second finned tube section **100B** are aligned adjacent one another so that the longitudinal axes A-A of the first and second finned tube sections **100A**, **100B** are substantially aligned and coaxial. When so aligned, the first end **115B** of the second tube **110B** of the second finned tube section **100B** abuts the second end **116A** of the first tube **110A** of the first finned tube section **100A**.

While the first and second finned tube sections **100A**, **100B** are aligned so that their longitudinal axes A-A are aligned, the first and second finned tube sections **100A**, **100B** (which are adjacent finned tube sections in the finned tube **200**) are rotated relative to one another so that corresponding ones of their fins, **111A**, **111B** are angularly offset from one another. This can improve heat transfer from the tube-side fluid (e.g., steam) to the shell-side fluid (e.g., air). The angular offset, in one embodiment is 1° to 20°. In another embodiment, the angular offset is 5° to 10°.

This concept will be described below with respect to an example to ensure understanding. Assume that the first finned tube section **100A** was placed in proper alignment and position in an angular/rotational position in which one of its fins **111A** were angularly located at each of the cardinal points (N, S, E, & W). The second finned tube section **100B** would then be position in axial alignment with the first finned section **100A** in an angular/rotational position in which none of its fins **111B** were located at the cardinal points. Rather, the second finned section **100B** would be in an angular/rotational position in which one of its fins **111B** is offset from each of the cardinal points by the angular offsets described above, such as for example 5° to 10°. In alternate embodiments, however, the fins **111A**, **111B** of the first and second finned sections **100A**, **100B** may be angularly aligned if desired.

Once the first finned tube section **100A** and second finned tube section **100B** are aligned and rotationally oriented as described above, the first and second finned tube sections **100A**, **100B** are coupled together, thereby forming the finned tube **200**. The exact technique used to couple, either directly or indirectly, the first finned tube section **100A** and second finned tube section **100B** together will depend on the material(s) of which the first finned tube section **100A** and second finned tube section **100B** are constructed. Suitable connection techniques include mechanical fastening in

which gaskets or other materials can be used achieve a hermetic interface, welding, brazing, thermal fusing, threaded connection, use of a coupler sleeve, a tight-fit connection, and/or combinations thereof. As described below with respect to FIGS. 8-10, coupling of the first and second finned tube sections **100A**, **100B** can also be accomplished using an inner tube.

While the finned tube **200** is exemplified as having only two finned tube sections **100A**, **100B**, the finned tube **200** can be formed of more or less finned tube sections **100A** as desired. In embodiments of the finned tube **200** in which more than two finned tube sections **100A**, **100B** are used, the aforementioned rotational offset can be implemented between each pair of adjacent finned tube sections.

Referring now to FIG. 5, an air-cooled condenser **1000** according to an embodiment of the present invention is illustrated. The air-cooled condenser **1000** is a true counter-current/parallel flow air-cooled condenser that, in one embodiment, is constructed with the finned tubes **200** formed of extruded aluminum or aluminum alloy finned tube section **100A**, **100B** in a vertical array (or matrix) configuration.

The air-cooled condenser **1000** generally comprises a shell **300** and a tube bundle assembly **400**. The tube bundle assembly **400** is positioned within an internal cavity **301** of the shell **300**. The shell **300** has an open top end **302** and an open bottom end **303**. As a result, cool air can flow into the open bottom end **302**, flow through the internal cavity **301** where it flows adjacent the finned tubes **200** and becomes warmed, and exits the shell **300** as warmed air. A blower **304**, in the form of a fan or other mechanism capable of inducing air flow, can be provided either above and/or below the tube bundle assembly **400**. While a single blower **304** is illustrated, more blowers can be implemented as desired to meet functional demands. In other embodiments, the blower may be omitted.

The tube bundle assembly **400** generally comprises a tube bundle **500** formed by a plurality of the finned tubes **200**, a top header pipe **410**, a bottom header pipe **420**, and a plurality of feeder pipes **430**. Each of the plurality of the finned tubes **200** of the tube bundle **500** are oriented in a substantially vertical orientation so that the longitudinal axes A-A (FIG. 2) thereof extend substantially vertical. The finned tubes **200** of the tube bundle **500** may be arrayed in a triangular, rotated triangular, rectangular or another suitable layout that provides for a uniformly distributed flow area across the tube bundle. In the exemplified embodiment, the finned tubes **200** of the tube bundles **500** are arrayed in 3x5 rectangular arrays (see FIG. 6). A desired feature of the tube bundle layout geometry is the ability to make a closely packed bundle of the finned tubes **200** such that the air flowing axially along the finned tubes **200** is in close proximity to the finned tubes' **200** outer surfaces. Factory assembled modules can be delivered and connected into the steam distribution network of a Rankine cycle fluid circuit of a power generation plant, thereby providing an economical heat rejection alternative for small and large scale applications.

Each of the finned tubes **200** of the tube bundle **500** is coupled to and fed steam from the top header pipe **410**, which is in turn operably coupled to a source of steam, such as turbine in a Rankine cycle power generation circuit. Similarly, each of the finned tubes **200** of the tube bundle **500** is coupled to the bottom header pipe **420** so that condensate can gather and be fed back into the Rankine cycle fluid circuit of the power generation plant. In the exemplified embodiment, a top end **201** of each of the finned

tubes **200** of the tube bundle **500** is fluidly coupled to the top header pipe **410** by a separate upper feeder pipe **430**. Similarly, a bottom end **202** of each of the finned tubes **200** of the tube bundle **500** is fluidly coupled to the bottom header pipe **420** by a separate lower feeder pipe **430**. As a result, a hermetic fluid path is formed through the cavity **113A** (FIG. 2) of each of the finned tubes **200** from the inlet header cavity **411** of the top header pipe **410** to the outlet header cavity **421** of the bottom header pipe **420**. The top header pipe **410** is located at an elevation that is greater than the elevation at which the bottom header pipe **420** is located. The top header pipe **410** and the upper feeder pipes **430** can be collectively considered a top network of pipes **470** while the bottom header pipe **420** and lower feeder pipes **430** can be collectively considered a bottom network of pipes **480**.

The top header pipe **410** extends along a longitudinal axis B-B (FIG. 5) that is substantially horizontal. Similarly, the bottom header pipe **420** also extends along a longitudinal axis that is substantially horizontal. In other embodiments, the top and bottom header pipes **410**, **420** may be inclined.

The top header pipe **410** is located above the tube bundle **500** while the bottom header pipe **420** is located below the tube bundle **500**. The top and bottom header pipes **410**, **420**, however, are specifically designed so as to create minimal impedance and/or obstruction to the vertical flow of air entering and exiting the tube bundle **500**. In order to accomplish this, each of the top and bottom header pipes **410**, **420** is designed to have a transverse cross-section having a major axis A_{MAJ} and a minor axis A_{MIN} . Moreover, each of the top and bottom header pipes **410**, **420** is oriented so that the minor axis A_{MIN} extends substantially perpendicular to the direction of the air flow through the tube bundle **500**. Thus, in the exemplified embodiment, the minor axis A_{MIN} extends substantially horizontal while the major axis A_{MAJ} extend substantially vertical. The major axis A_{MAJ} has a length that is larger than the length of the minor axis A_{MIN} for both the top and bottom header pipes **410**, **420**. In one such embodiment, the major axis A_{MAJ} has a length that is at least twice the length of the minor axis A_{MIN} for both the top and bottom header pipes. By designing and orienting the transverse cross-sections of the top and bottom header pipes **410**, **420** to have the aforementioned major axis A_{MAJ} and minor axis A_{MIN} , the top and bottom header pipes **410**, **420** achieve two criteria: (1) adequate flow area for the tube side fluid; and (2) maximum opening between the adjacent headers to minimize friction loss to the entering (bottom header) and exiting (top header) air (see FIG. 6 also). While not visible from the drawings, each of the horizontal sections of the feeder pipes **430** may also be designed to have a transverse cross-section comprising a major axis A_{MAJ} and a minor axis A_{MIN} , and be oriented, as discussed above and below with respect to the top and bottom headers **410**, **420**.

In one embodiment, the top and bottom header pipes **210**, **220** (along with the horizontal sections of the feeder pipes **430**) each have an obround transverse cross-section. The obround shape allows for a large internal flow area for steam while affording ample space for the air to enter and exit the tube bundle **500** via spaces between the header pipes **410**, **420** (and horizontal sections of the feed pipes **430**). The obround transverse cross section with the flat (long) sides vertical is a preferred arrangement when the tube side fluid is low pressure steam or vapor. As mentioned above, the top header pipe **510** serves as the inlet for the vapor (exhaust steam) (see FIG. 3 for a typical inlet header profile).

As can be seen in FIG. 6, the air-cooled condenser can comprises a plurality of tube bundles **500** housed in separate shells **300**. In other embodiments, more than one tube

bundle **500** can be housed in a single shell **300**. All of the inlet header pipes **410** are preferably manifolded from a single point **450** of a main steam supply line **440**. Furthermore, each of the tube bundles **5X**, along with the shell **300** may be positioned atop a fan deck, which is in turn positioned atop a frame structure (as shown in FIG. 1).

Referring back to FIG. 5, the up flowing cooling air may be sprayed with a mist of coolant generated by spray nozzles **550** located within the shell **300** at a height between the top header pipe **410** and the bottom header pipe **420**. The spray nozzles **550** are operably and fluidly coupled to coolant reservoirs **551** and further configured to atomize the liquid coolant into a fine mist that is introduced into the air flowing through the tube bundles **500**. Spaying the mist into the air flow at intermediate height(s) increases the LMTD and promotes heat rejection from the tube side fluid (i.e. the steam). This form of cooling augmentation is unique to this heat exchanger design and results in substantial performance gains of 25 to 30% depending on the ambient conditions. These performance gains can be realized in improved warm weather performance or capital cost reduction and smaller plot area constraints.

Referring now to FIG. 7, a housing **300** suitable for use in the air-cooled condenser **1000** of FIGS. 5 and 6 is illustrated. Depending on the available height, a "chimney" space **305** above the bundle can be incorporated in the unit to increase the natural draft height. This will reduce the amount of electrical energy required to pump the cooling air through the bundle. In designs where the blower **304** is located above the tube bundle **500**, it is possible to provide for additional entry windows **310** for air to enter the tube bundle **500**, which will promote increased heat transfer from the tube-side fluid.

Referring now to FIGS. 8-10, an alternative construction of the finned tube **2000** is described in which the final finned tube **2000** comprises the finned tube sections **100A**, **100B** and an inner tube **700**. Such an arrangement is particularly useful in power plants where the condensing steam is not permitted to come in contact with aluminum or aluminum alloy of the finned tube sections **100A**, **100B**. The finned tube **2000** can be used in the air-cooled condenser **1000** described above in lieu of or in addition to the finned tubes **200**.

Referring first to FIG. 8, the first and second finned tube sections **100A**, **100B** are formed, aligned and oriented as described above with respect to FIGS. 2-4. Once this is done, an inner tube **700** is provided and axially aligned with the cavities **113A**, **113B** of the first and second finned tube sections **100A**, **100B** along a longitudinal axis C-C. The inner tube **700** is formed of a material that is different than the material of which the first and second finned tube sections **100A**, **100B** are formed. In one embodiment, the inner tube **700** is formed of a material having a high yield strength, is non-corrosive, and is weldable. A suitable material includes steels, with stainless steel being preferred.

The inner tube **700** extends along an axis has an outer surface **702** and inner surface **701**, which forms cavity **703**. The inner tube **700** extends from a bottom end **705** to a top end **704** along the longitudinal axis C-C.

Referring now to FIGS. 9 and 10 concurrently, the inner tube **700** is then slid through the cavities **113A**, **113B** of the finned tube sections **100A**, **100B**. In the exemplified embodiment, the top end **704** of the inner tube **700** protrudes slightly from the top end of the first finned tube section **100A** while the bottom end **705** of the inner tube **700** protrudes slightly from the bottom end of the second finned tube section **100B** (FIG. 9). At this stage, the outer diameter of the

inner pipe 700 is smaller than the inner diameter of the tubes 110A, 110B. As a result, a interstitial space 750 exists between the outer surface 702 of the inner tube 700 and the inner surfaces 112A, 112B of the tubes 110A, 110B.

Once the inner tube 700 is so positioned, the inner tube 700 is diametrically expanded by applying a force F. Diametric expansion of the inner tube can be achieved by a variety of methods, including hydraulic pressure.

Referring now to FIG. 11, the diametric expansion of the inner tube 700 continues until the outer surface 702 of the inner tube 700 is in substantially conformal surface contact with the inner surfaces 112A, 112B of the finned tube sections 100A, 100B, thereby forming the finned tube 2000. As a result the interstitial space 750 disappears and there are substantially no gaps and/or voids between the outer surface 702 of the inner tube 700 and the inner surfaces 112A, 112B of the finned tube sections 100A, 100B. In embodiments using the inner tube 700, the tubes 110A, 110B can be considered outer tubes.

The inner tube 700 couples the finned tube sections 100A, 100B together and thus can be used instead of or in conjunction with the other coupling techniques discussed above for FIG. 4. When the resulting finned tube 2000 is incorporated into the air-cooled condenser 1000, the inner tube 700 can be used to make the welded joints between the top pipe network 470 and/or the bottom pipe network 460, as shown in FIG. 5. Additionally, when the inner tube 700 is used, the first and second inner tubes 100A, 100B do not have to be in abutment to effectuate coupling. Because the inner tube 700 (in contact with the condensing steam) is at a higher temperature than the finned tube sections 110A, 100B, the risk of the inter-tube interface becoming loose during service is ameliorated.

Example

Comparison of a conventional (inclined bundle) air-cooled condenser (FIG. 1) and an air-cooled condenser according to the present invention is set forth below in the following table for the performance of the two design concepts:

| | Conventional A-Frame ACC | HI-VACC | Percent Difference |
|--|-----------------------------|-----------|-----------------------|
| Thermal Duty, mmBtu/hr | 860 | 860 | — |
| Condensing Pressure, "HgA | 2.0 | 2.0 | — |
| Ambient Air Temperature, ° F. | 60 | 60 | — |
| Number of Cells Required | 20 | 12 | -40% |
| ACC Plot Area (L × W), ft | 238 × 170 | 240 × 80 | -53% |
| ACC Height, ft | 104 | 79 | -24% |
| Total Extended Heat Transfer Surface, ft ² | 8,919,200 | 7,977,250 | -10% |
| Total Fan Shaft Power, kW | 2700 | 2700 | — |

The design concepts disclosed herein can be used in a wide variety of coolers that seek to employ air as the cooling medium. Its application to design air cooled condensers to condense exhaust steam in power plants will lead to reduced cost and reduced land area requirement. Additional advantages of the present invention are: (1) modular installation; (2) reduced site construction effort compared to the A-frame design; (3) significantly reduced quantity of structural steel required to erect the system; and (4) ability to reduce fan power consumption by adding an exhaust stack (chimney) to the design.

As used throughout, ranges are used as shorthand for describing each and every value that is within the range. Any value within the range can be selected as the terminus of the range. In addition, all references cited herein are hereby incorporated by referenced in their entireties. In the event of a conflict in a definition in the present disclosure and that of a cited reference, the present disclosure controls.

While the invention has been described with respect to specific examples including presently preferred modes of carrying out the invention, those skilled in the art will appreciate that there are numerous variations and permutations of the above described systems and techniques. It is to be understood that other embodiments may be utilized and structural and functional modifications may be made without departing from the scope of the present invention. Thus, the spirit and scope of the invention should be construed broadly as set forth in the appended claims.

What is claimed is:

1. A method of forming a finned tube for an air-cooled condenser, the method comprising:

extruding, from a first material, a first finned tube section comprising:

a first tube having an inner surface forming a first cavity along a first longitudinal axis and an outer surface; and

a first plurality of fins protruding radially outward from the outer surface of the first tube, the first plurality of fins integral with the first tube and extending substantially parallel to the first longitudinal axis;

extruding, from the first material, a second finned tube section comprising:

a second tube having an inner surface forming a second cavity along a second longitudinal axis and an outer surface; and

a second plurality of fins protruding radially outward from the outer surface of the second tube, the second plurality of fins integral with the second tube and extending substantially parallel to the second longitudinal axis;

aligning the first finned tube section and the second finned tube section so that the first and second longitudinal axes are in axial alignment and the first and second plurality of fins are angularly offset from one another; abutting a first end of the first finned section to a second end of the second finned tube section; and

hermetically coupling the abutting first and second ends of the first and second finned sections directly together wherein a hermetic fluid path is formed through the first and second cavities of the first and second tubes.

2. The method according to claim 1 further comprising inserting an inner tube having an outer surface through the first cavity and expanding the inner tube so that the outer surface of the inner tube is in substantially conformal contact with the inner surface of the first tube.

3. The method according to claim 2 wherein the inner tube is formed of a second material that is different than the first material.

4. The method according to claim 3 wherein the first material is aluminum or aluminum alloy and the second material is stainless steel.

5. The method according to claim 2 wherein the inner tube is expanded using a hydraulic expansion technique.

6. The method according to claim 1 wherein the first tube has a substantially circular transverse cross-section.

7. The method according to claim 1 wherein the first plurality of fins are arranged at uniform angular intervals around the circumference of the first tube, and the second

plurality of fins are arranged at uniform angular intervals around the circumference of the second tube.

8. The method according to claim 1 wherein each fin of the first plurality of fins is angularly offset from a corresponding fin of the second plurality of fins by 1 to 20 degrees.

9. The method according to claim 1 wherein said coupling of the first and second finned sections together comprises: inserting an inner tube having an outer surface through the first cavity and the second cavity; and expanding the inner tube so that the outer surface of the inner tube is in substantially conformal contact with the inner surface of the first tube and the inner surface of the second tube.

10. The method according to claim 1 wherein the first tube has a substantially circular transverse cross-section.

11. A method of forming a finned tube for an air-cooled condenser, the method comprising:

providing a plurality of finned tube sections, each finned tube section comprising: an outer tube having an inner surface forming a cavity along a longitudinal axis and an outer surface; and a plurality of fins protruding radially outward from the outer surface of the outer tube, the outer tube formed of a first material;

aligning the finned tube sections so that the longitudinal axes of each finned tube section are in axial alignment and the plurality of fins of each finned tube section is angularly offset in orientation from each adjoining finned tube section;

abutting ends of the plurality of finned tube sections together; and

hermetically coupling each of the abutting ends of the finned tube sections directly together wherein a hermetic fluid path is formed through the cavities of the plurality of finned tube sections;

inserting an inner tube having an outer surface through the cavities of the outer tubes of the coupled finned tube sections, the inner tube having an inner surface forming a cavity; and

expanding the inner tube so that the outer surface of the inner tube is in contact with the inner surfaces of the outer tubes, the inner tube formed of a second material that is different than the first material.

12. The method according to claim 10 wherein the first material is aluminum or aluminum alloy and the second material is a weldable material having a high yield strength.

13. The method according to claim 12 wherein the second material is a steel.

14. The method according to claim 12 wherein the inner tube is expanded using a hydraulic expansion technique.

15. The method according to claim 12 wherein the outer tube and the inner tube have a substantially circular transverse cross-section.

16. The method of according to claim 12 wherein the expanding step is performed until the outer surface of the inner tube is in substantially conformal contact with the inner surface of the outer tube.

17. A method of forming a finned tube for an air-cooled condenser, the method comprising:

forming a plurality of finned tube sections, each of the finned tube sections comprising:

a tube having an inner surface forming a cavity along a longitudinal axis and an outer surface; and a plurality of fins protruding radially outward from the outer surface of the tube;

aligning the plurality of finned tube sections so that the longitudinal axes are in axial alignment and the plurality of fins of adjacent finned tube sections are angularly offset from one another;

abutting ends of the plurality of finned tube sections together; and

hermetically coupling each of the abutting ends of the finned tube sections directly together wherein a hermetic fluid path is formed through the cavities of the plurality of finned tube sections.

18. The method according to claim 17 wherein for each of the plurality of finned sections, the plurality of fins are arranged at uniform angular intervals around the circumference of the tube.

19. The method according to claim 17, wherein more than two finned tube sections are formed, aligned, abutted, and hermetically coupled together, and wherein the plurality of fins of each adjacent pair of finned tube sections are angularly offset from one another.

* * * * *